

Cross rhythm: a passage in which a different meter is temporarily expressed or implied, while the prevailing meter continues underneath

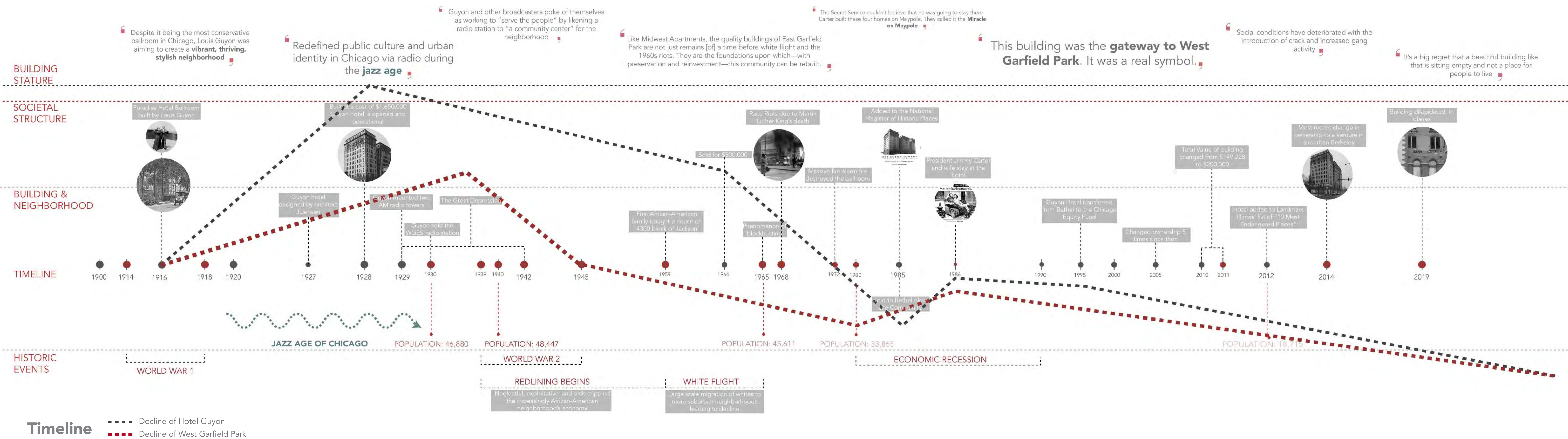

Cross Rhythm is a destination in West Garfield Park for all Chicagoans. The historic Hotel Guyon, developed by a jazz club owner and once housing radio stations, is going back to its roots.

The refurbished building will be a hub for all to enjoy jazz performances, understand the history of jazz in Chicago at the museum, and learn to play musical instruments. The building will also include a venue space for any community or personal event located at the top of the building, and a public café at the base.

West Garfield Park has the infrastructure to support this project as a destination via its proximity to public transportation – Chicagoans can journey for a show or museum outing. There are a number of schools around this residential area which support the music school. It provides a neighborhood café hangout nearby the public park which hosts an array of park district sports.

The project goal is provide transparency and openness not only to the building, but to West Garfield Park. Cross Rhythm will bring revenue and people into the area, boosting jobs and decreasing crime. By bringing new life and connection, all Chicagoans will cross paths here.

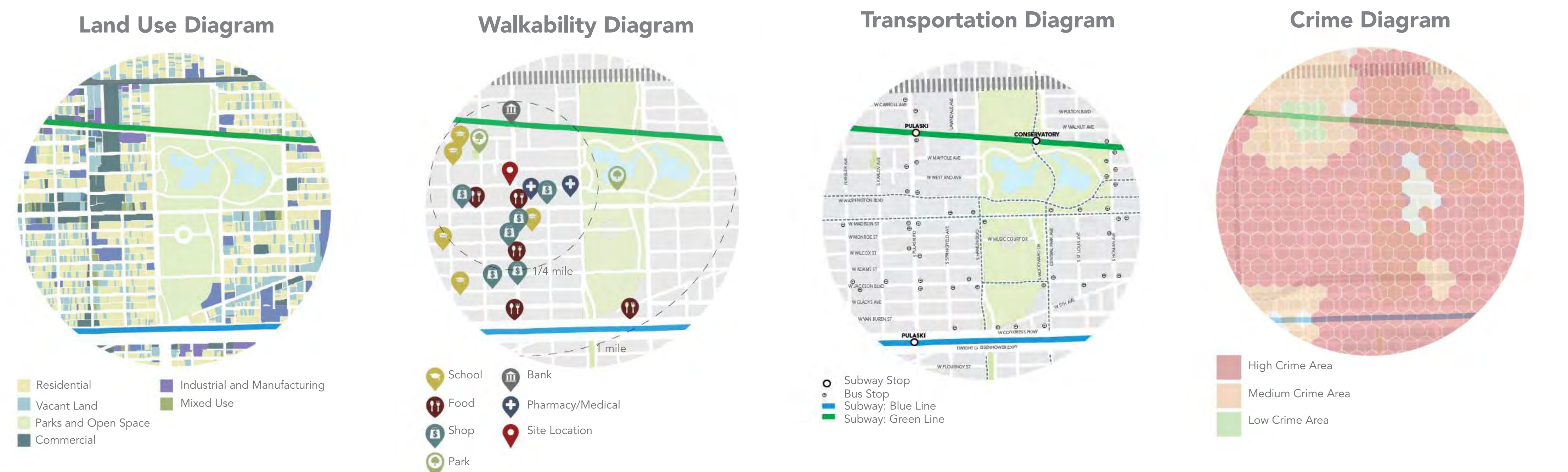

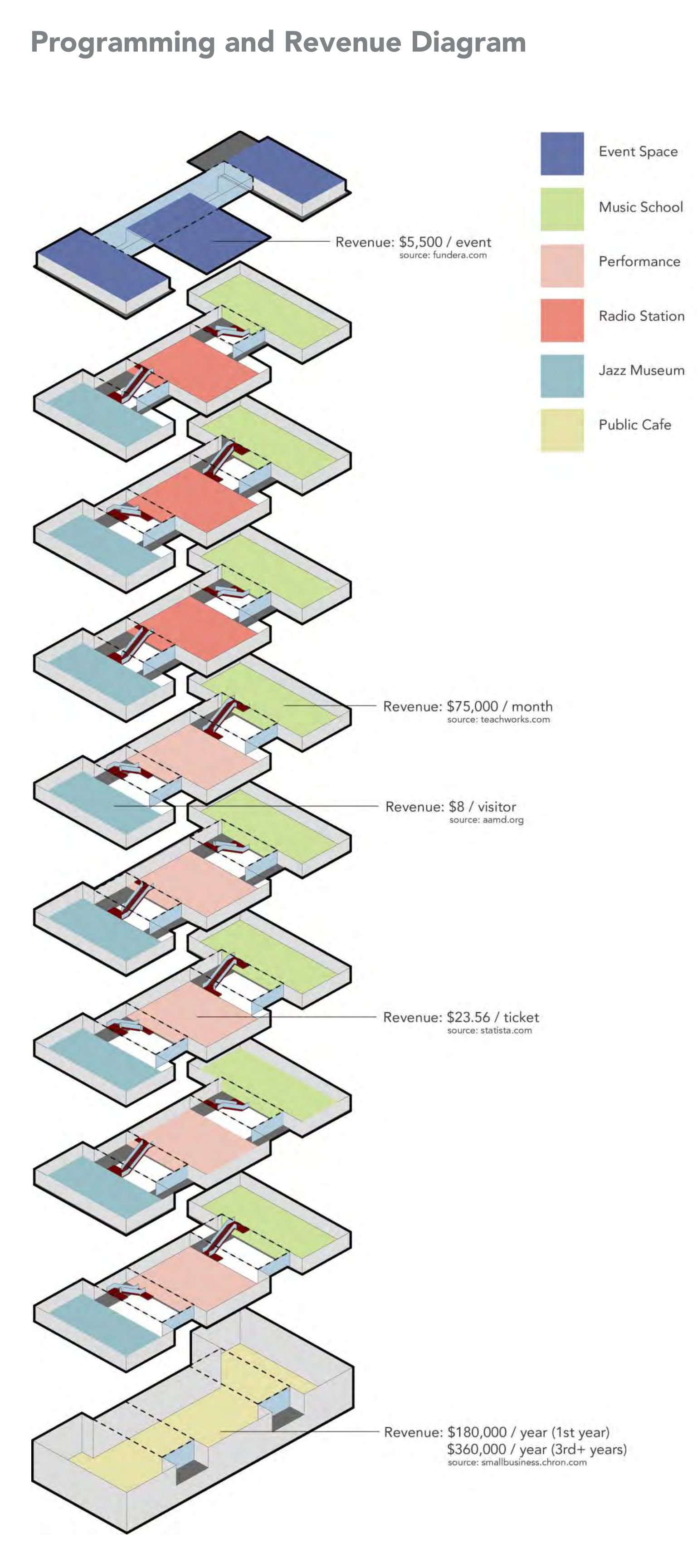
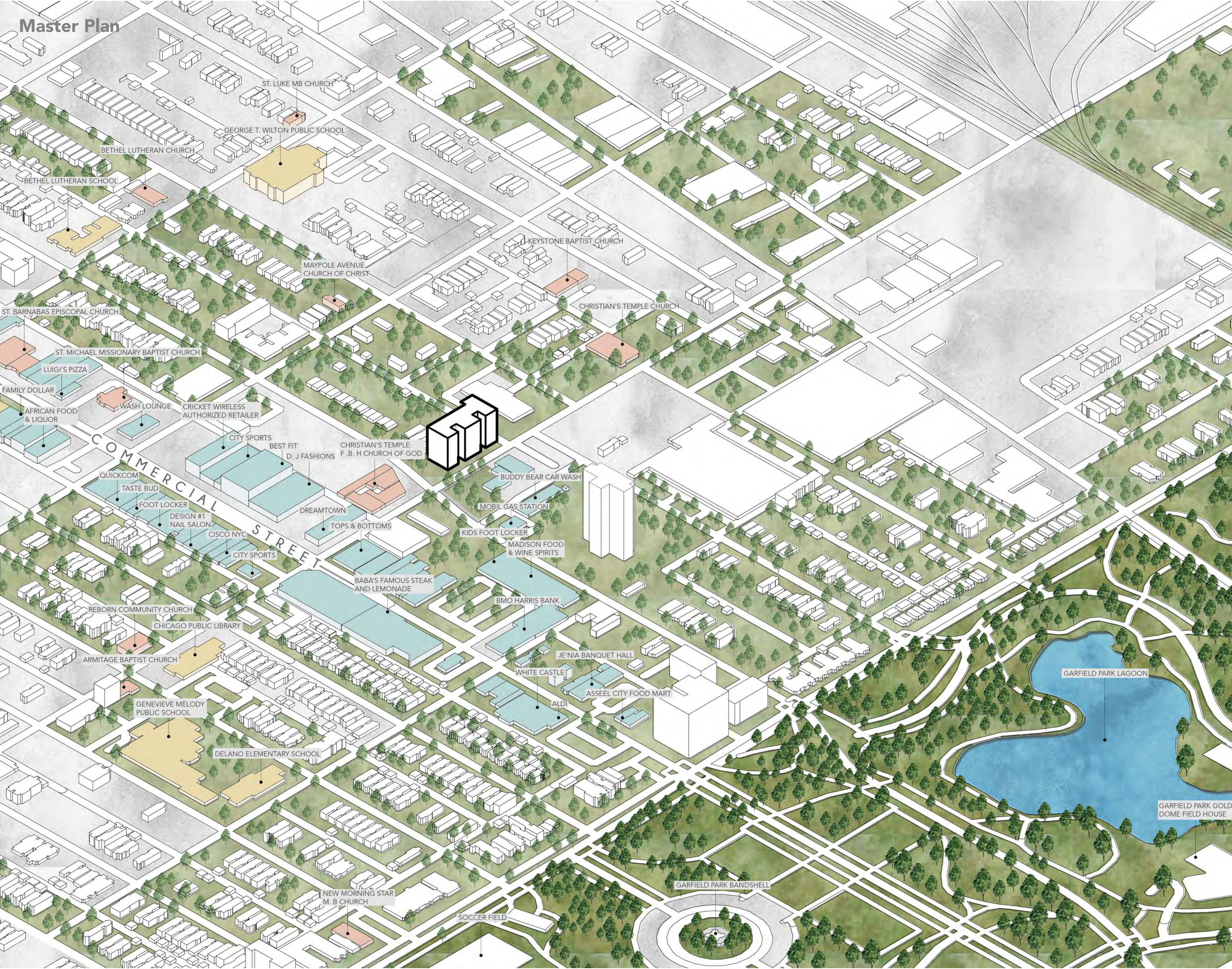

Massing Diagram

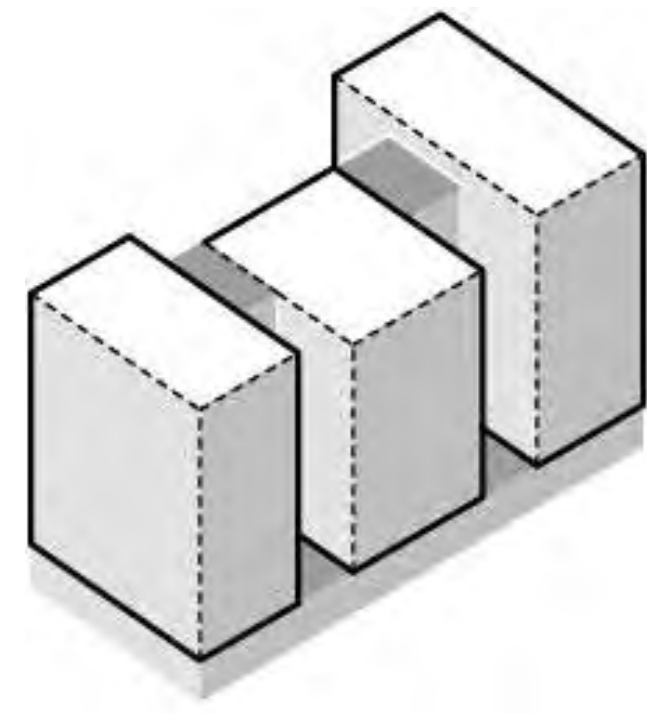

The **three towers** of the existing Hotel Guyon building create the natural choice for division of **building program**.

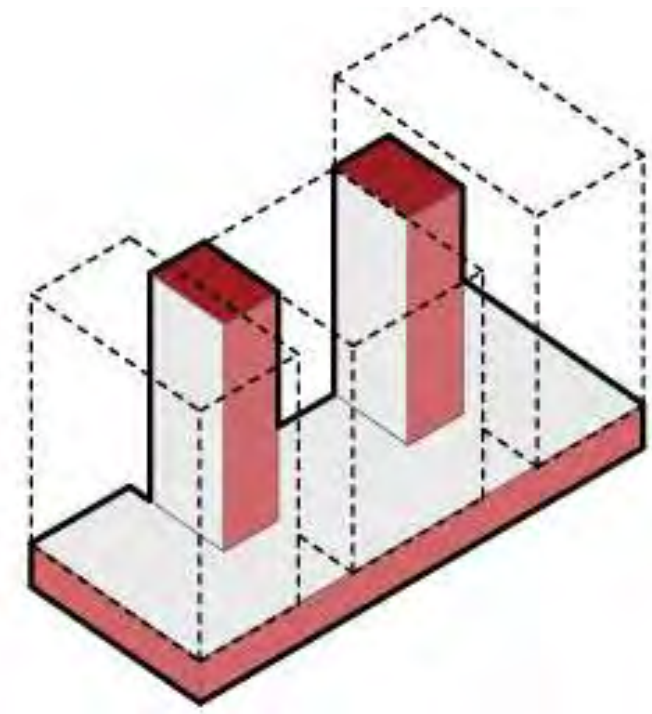

Isolating the wells between the towers allows for connection of program via **circulation**.

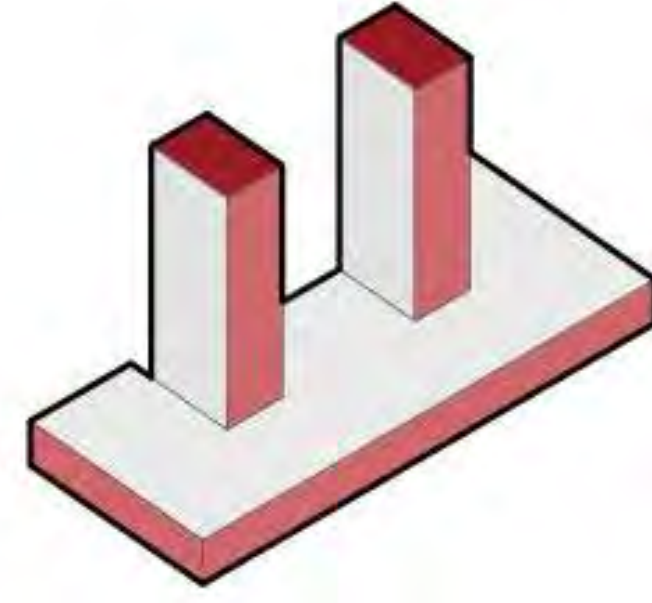

The **building base** acts as **circulation** and the transition from the community into the building.

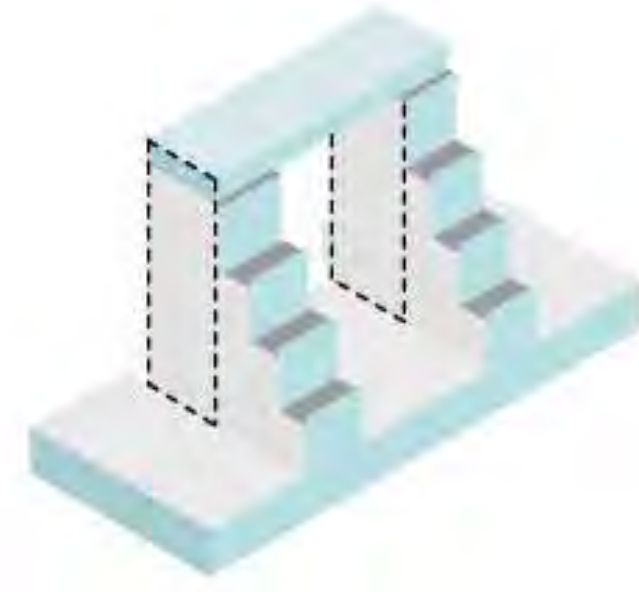

The **circulation areas** are **clad in glass**, representing transparency and openness to the community and city as a whole.

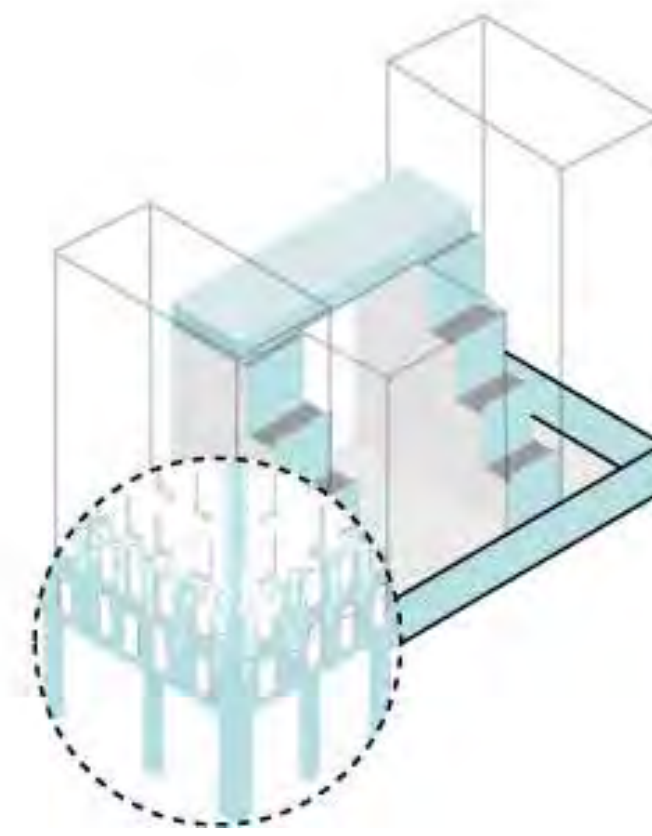

Glass bricks are used at the building base as a transitional transparent layer, utilizing the **visual language of the existing structure**, while connecting it to the current community and context.

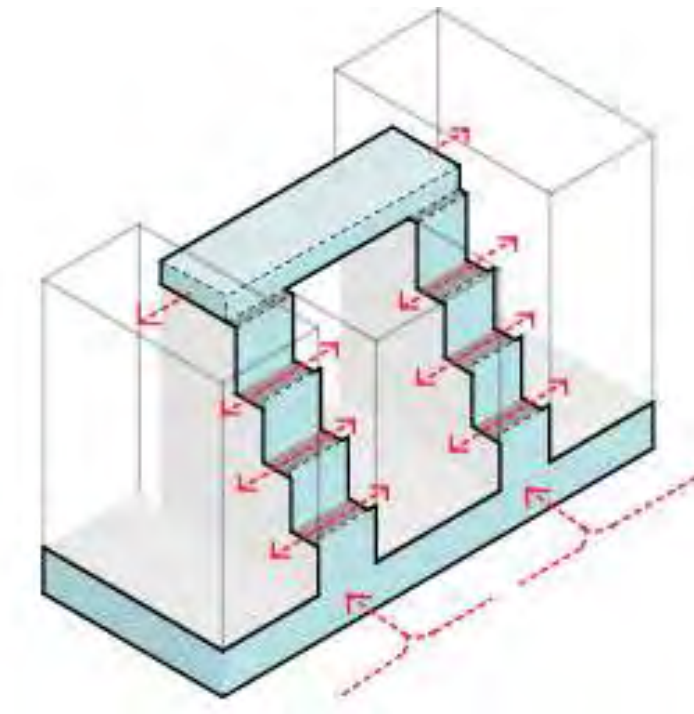

Each **program** is **connected by the transparent circulation**, providing dynamic connections not only within the building but to the outside.

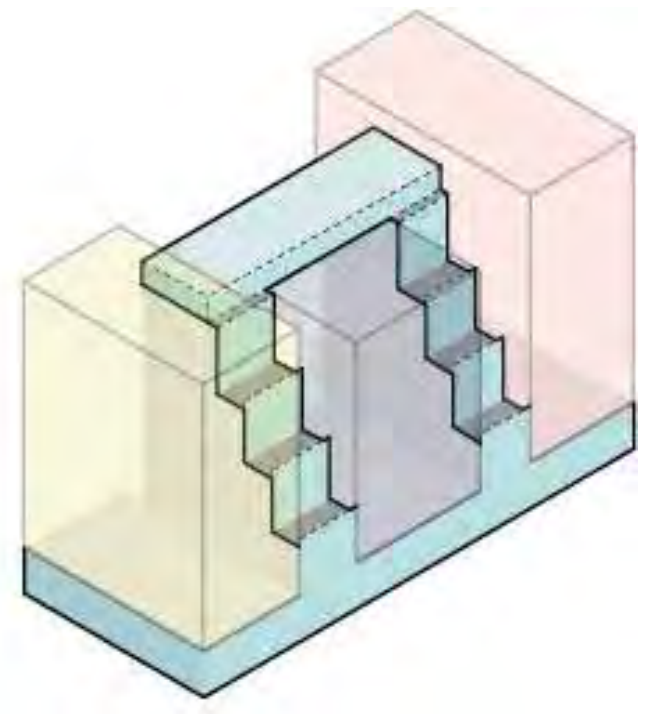

The **jazz museum** at the corner tower is rooted in the neighborhood and history. The middle tower houses the **performance hall and radio station**, the central force of the building. The final tower is a **school** for all to learn to play music.

Exterior Perspective



Interior Perspective



Section Perspective

